

International iQFOiL Class Association Executive Committee Meeting

MINUTES

Date and time: 09th of September 2024 – 13h30 CET

Place: Online via the Zoom conferencing system

In attendance:

List of Attendees

- Ronnie Meir - President of the iQFOiL Class
- Gonzalo Costa Hoevel - iQFOiL Class Manager
- Valérie Boutet Massonneau - iQFOiL Class Executive Secretary
- Ewa Jodlowska (POL)
- Barrie Edgington (GBR)
- Adrien Gaillard (USA)
- Piotr Myszka (POL)
- Lorand Utassy (until 13:50) (HUN)

Guest

- Kiran Badloe (NED) - World Sailing Athletes Representative

List of Absentees

- Peina Chen (CHN)
- Mariana Aguilard (MEX)
- Nicolas Goyard (FRA)

REFLECTIONS ON THE MEDAL RACES FORMAT FOR THE LA 2028 OLYMPIC GAMES

The Executive Committee gathered to discuss the format of the Medal Races Series in response to a request from the World Sailing LA 2028 Olympic Games Format Working Party. World Sailing has expressed its preference for no more than two different Medal Races Series formats to coexist across Olympic sailing disciplines. The purpose of the meeting was to debrief the experiences from the Paris 2024 Olympics and assess whether any adjustments are needed for the next Olympiad. The objective was to develop a project proposal for presentation at the upcoming World Sailing Annual Conference in Singapore, scheduled from November 4 to 9, 2024.

1.1. Key Discussion Points:

- The Executive Committee acknowledge World Sailing concern about having a Medal Races Series format that is understandable to a broad audience and media-friendly,
- The Executive Committee acknowledge World Sailing concern not to have more than two different Medal Races Series formats to coexist across Olympic sailing disciplines,
- Another crucial consideration was however to ensure the Medal Races Series format adequately reflects the athletes' journey through a championship, the Olympic Games, and even the entire Olympic cycle,
- In light of the limited media coverage of sailing at the Paris Olympics, the Executive Committee members are questioning whether the fairness of the races should be compromised for a format that fails to attract additional media attention.

1.2. Alternative Studied: The Current iQFOiL Medal Series Format

- **The current format features a three-stage Grand Final system**
- Quarter-Final:
7 athletes ranked 4th to 10th.

- Semi-Final:
4 athletes, with the 2nd and 3rd overall rankings protected and two quarter-final winners advancing
- Final:
3 athletes, with the overall leader protected and two semi-final winners advancing.

- **Observation on Paris 2024**

- The pressure on athletes was highlighted, citing Emma Wilson (GBR) as an example of the high stakes involved in the final race, but also Pawel Tarnowski (POL) and H el ene Noesmoen (FRA).
- While athletes are aware of the format in advance, the potential for equipment failure or other mishaps could unfairly determine the outcome, especially if it occurs during the Grand Final.

- **Changes to current format discussed**

A suggestion was made to adapt the kiteboarding series' approach to the iQFOIL Grand Final:

The top 3 overall would automatically qualify for the Grand Final, followed by a two-stage Medal Races Series:

1. **Semi-final repechage:** Sailors ranked 4th to 8th would compete in a repechage round, with the winner joining the top 3 in the Grand Final.

2. **Grand Final of 4 sailors:** The leader would start with two wins, the second-ranked with one, while the third and fourth would have none. The first sailor to win three races would take the gold:

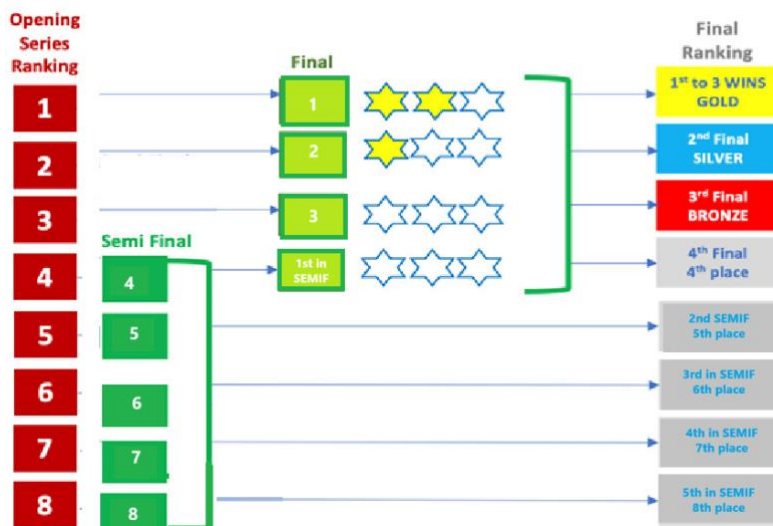

However, several members voiced concerns, arguing that despite these adjustments, the format still relies on a single decisive race, which does not truly reflect the values of sailing.

1.3. Discussion of other format alternatives

- **Top 8 Finals Format**

An alternative format was considered:

- The top 8 sailors from the Opening Series Races qualify for the finals.
- The overall classification from the Opening Series Races would either count as the first race or as the first race with double points.
- 3 additional races would be held with no discard.
- The final ranking would be determined by the total score from these 4 races.

- **Advantages**

- This format avoids the knock-out system, which some members felt misrepresents the nature of sailing.
- The three-race format is engaging, easy to understand, and allows for live position updates, making it media-friendly and spectator-friendly.
- Other sports such as surfing and archery already use similar formats, demonstrating its viability for the Olympic stage.

- **Athletes Well-being**

- The Executive Committee also discussed scheduling concerns, proposing races programming that better accommodates athletes' physical demands:

- 2 days of racing
- 1 spare day
- 2 more days of racing
- Medal Race day
- 1 spare Medal Race day

- This proposed schedule, although involving four main racing days, leaves room for a fifth in case of poor weather forecasts.

1.4. Consistency Across Olympic Classes

- A critical point raised was the need for all Olympic Sailing Classes to compete under the same Medal Races Series format in LA 2028.

- Members strongly opposed continuing to use iQFOiL as an experimental Class, advocating for a unified and simple system across all Olympic Sailing Classes.

1.5. Athletes Survey

- A survey will be conducted among athletes from the previous Olympiad to gather input on the LA 2028 Medal Series format.

- The results of this survey will inform the final proposal to be submitted to the World Sailing LA 2028 Olympic Games Format Working Party before the World Sailing Annual Conference.

Conclusion

The meeting concluded with a general agreement that while adjustments to the current format are essential to ensure fairness and more accurately reflect the athletes' journey during an event and sailing as a sport, any changes must also maintain simplicity, be accessible to media, and consistent across all Olympic classes. The Executive Committee decided to gather additional input from athletes and finalize a proposal ahead of the World Sailing Annual Conference.

The Executive Committee Meeting ended at 14h56